

# TRANSFORMER

## Products Catalogue



**HONLE GROUP CO.,LTD.**

Add: No.201 wei 16 Road,Yueqing Economic Development Zone,Zhejiang Province 325600.P.R,China

Tel: 86-577-61755578  
Fax: 86-577-61755177

E-mail: sales@honle.com  
Http: www.honle.com

# HONLE GROUP



**25<sup>th</sup>**

Founded in 1998

**30000<sup>sq.m.</sup>**

Plant area

**500<sup>+</sup>**

Employees

**5+100**

Five Marketing Centers + More than 100 Agents  
· Shanghai Honle Electric Co., Ltd.  
· Beijing Honle Electric Co., Ltd.  
· Zhengzhou Honle Electric Co., Ltd.  
· Wuhan Honle Technology Development Co., Ltd.  
· Wenzhou Honle Import and Export Co., Ltd.

**4<sup>P</sup>**

Four main departments:  
· Power Supply Department  
· Power Transformer Department  
· Switchgear Department  
· Circuit breaker Department

**30<sup>+</sup>**

Products are used in more than 30 countries and regions around the world

**50<sup>+</sup>**

Series of products have won more than 50 patents

HONLE GROUP CO.,LTD, (hereinafter referred to as "HONLE") established in May 1998, is a well-known company in manufacturing and supplying of various electrical equipments for power generation, transmission, distribution, and substations.

HONLE maintains world standard while manufacturing it's products. Manufactures products are:

- Transformers
- LV/HV Switchgear Panels
- Indoor/Outdoor Circuit Breakers
- Voltage Stabilizer
- Ring Main Unit
- Outdoor Reclosers
- Outdoor Load Break Switch
- Outdoor Disconnect switch
- Outdoor metering Kit
- Other important electrical equipments



## BRIEF INTRODUCTION

HONLE Group has started its journey since 1998. Now, HONLE has become one of the leading manufacturers in electrical industry in China. HONLE successfully has spread its business not only in China but also all over the world. After several years of continuous efforts, HONLE has made significant progress in terms of variety, production scale, and management method. As a result, HONLE's products have reached to a advanced technical level, and they become recognized by a large number of clients not only in China, but also in other countries.

HONLE has 30,000sq.m. plant area with over 500 employees. It has modern workshops and advanced manufacturing equipments so that HONLE can provide the products best in quality to its customer. All HONLE products are third party certified. HONLE has own testing equipment so that HONLE can ensure its errors. Also HONLE has researching team whom are working on the latest and upcoming technology. This makes HONLE as the advanced technical support in power sector for its valued customers.

HONLE has earned honor from Chinese Society of Power units, China People's Insurance Underwriting Certificate, and High-Tech Enterprises.

HONLE has also received ISO9001 Quality System Certificate, European CE Certification, SBW Series of Inspection Reports, SBW Series of Radio and Television Network that Certificate, SVC Series of Radio and Television Network that Certificate, and others.



# TRANSFORMER

## PRODUCT CONTENTS



01

**110KV**  
Oil Immersed  
Power Transformer



08

**S11-M**  
Oil Immersed  
Distribution Transformer

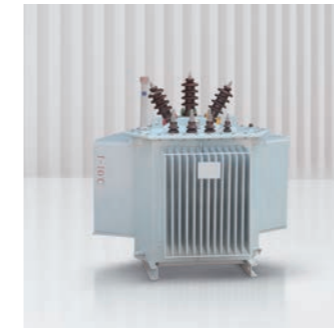

14

**S13-M.RL**  
Oil Immersed Wound Core  
Distribution Transformer



20

**SC(B)**  
Cast Resin Dry Type  
Transformer



04

**35KV**  
Oil Immersed  
Power Transformer



10

**S9-M**  
Oil Immersed  
Distribution Transformer



16

**SBH15-M**  
Amorphous Alloy  
Transformer



23

**SC(B)-RL**  
Cast Resin Wound Core  
Dry Type Transformer



06

**SZ11-M**  
On-load Oil Immersed  
Power Transformer



12

**S13-M**  
Oil Immersed  
Distribution Transformer



18

**D10-M**  
Single Phase Oil Immersed  
Distribution Transformer



25

**JP**  
Cabinet

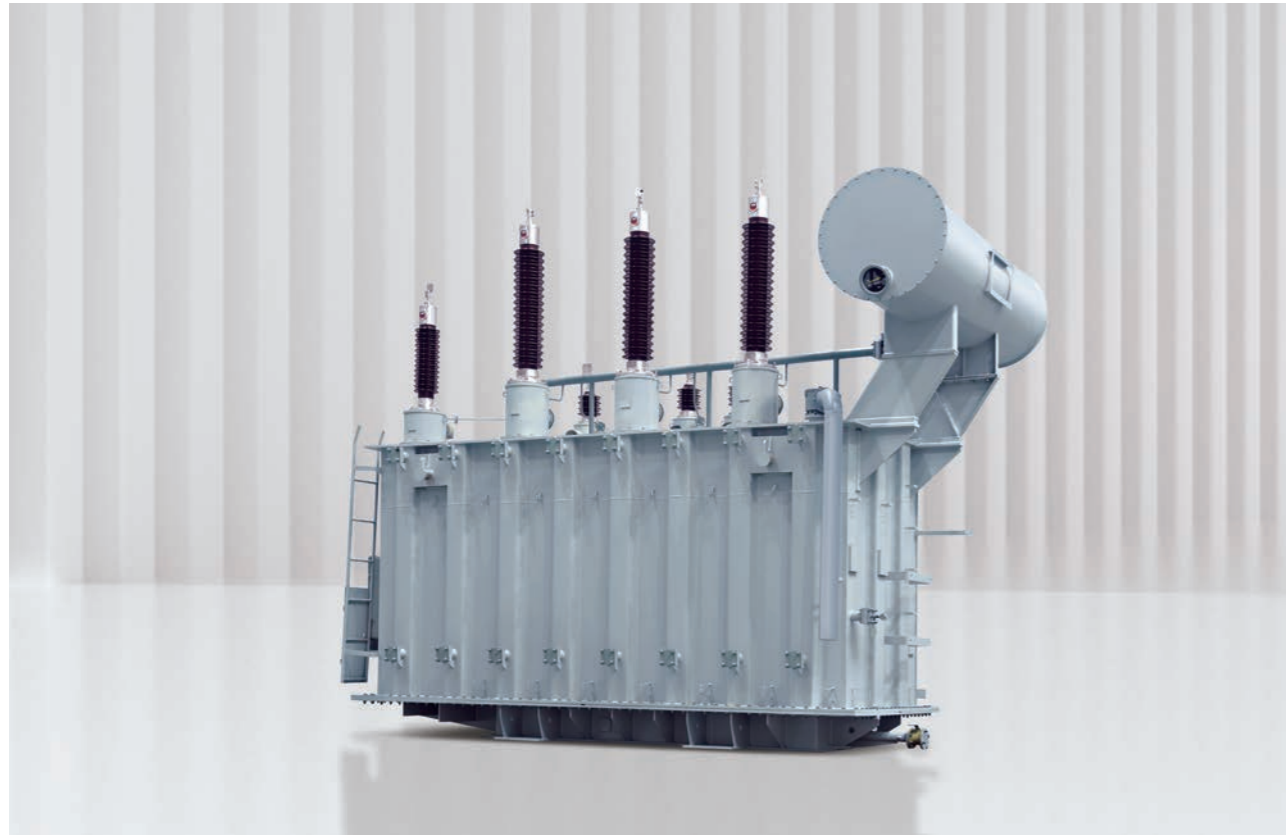

# 110kV Oil Immersed Power Transformers

## OVERVIEW

The core of 110kV power transformers is made of high-quality silicon-steel sheets, and laminated by steps. It is advantageous in low loss, low noise, and high short-circuit withstand capacity, etc. Now it is widely used in power station, power plant, and gets high praise from them. SZ11-63000/110 transformers have passed a complete set of National tests and the short-circuit withstand capacity test.

## TECHNICAL PARAMETERS

### 110kV Double -winding Power Transformers with On -load Tap -changer

Rated Capacity (kVA)	Voltage ratio (kV)			Vector Group	No-load Loss (kW)	No-load Current (%)	Full-load Loss (kW)	Impedance (%)	
	HV	Tapping Range	LV						
6300	110	±8× 1.25%	6.3	YNd11	10	0.6	36	10.5	
8000					12	0.6	45		
10000					14.2	0.55	53		
12500					16.8	0.55	63		
16000					20.2	0.5	77		
20000					24	0.5	93		
25000					28.4	0.45	110		
31500					33.8	0.45	133		
40000					40.4	0.4	156		
50000					47.8	0.4	194		
63000					56.8	0.35	234		
75000					63.4	0.35	278		
90000	73.1	0.3	320						
120000	91.2	0.3	397						

### 110kV Three -winding Power Transformers with On -load Tap -changer

Rated Capacity (kVA)	Voltage ratio (kV)			Vector Group	No-load Loss (kW)	No-load Current (%)	Full-load Loss (kW)	Impedance (%)	
	HV	MV	LV					Step -Down	Step -Up
6300	110	±8× 1.25%	6.3	YNyn0d11	12	0.6	47	10.5	H-M H-M
8000					14.4	0.6	56		
10000					17.1	0.55	66		
12500					20.2	0.55	78	17-18	H-L H-L
16000					24.2	0.5	95		
20000					28.6	0.5	112		
25000					33.8	0.45	133	17-18	H-L H-L
31500					40.2	0.45	157		
40000					48.2	0.4	189		
50000					56.9	0.4	225	6.5	M-L M-L
63000					67.7	0.35	270		

TECHNICAL PARAMETERS

66kV Double-winding Power Transformers with Off -circuit Tap -changer

Rated Capacity (kVA)	Voltage ratio (kV)			Vector Group	No-load Loss (kW)	No-load Current (%)	Full-load Loss (kW)	Impedance (%)
	HV	Tapping Range	LV					
6300	110 121	±2×2.5%	6.3 6.6 10.5 11	YNd11	9.2	0.6	36.0	9
8000					11.2	0.6	42.7	
10000					13.2	0.55	50.4	
12500					15.6	0.55	59.8	
16000					18.8	0.5	73.5	
20000					22.0	0.5	89.1	
25000					26.0	0.45	105.3	
31500					30.8	0.45	126.9	
40000					36.8	0.4	148.9	
50000					44.0	0.4	184.5	
63000	52.0	0.35	222.3					

66kV Double-winding Power Transformers with On -load Tap -changer

Rated Capacity (kVA)	Voltage ratio (kV)			Vector Group	No-load Loss (kW)	No-load Current (%)	Full-load Loss (kW)	Impedance (%)
	HV	Tapping Range	LV					
6300	63 66 69	±8×1.25%	6.3 6.6 10.5 11	YNd11	10	0.6	36.0	9
8000					12	0.6	42.7	
10000					14.2	0.55	50.4	
12500					16.8	0.55	69.8	
16000					20.2	0.5	73.5	
20000					24	0.5	89.1	
25000					28.4	0.45	105.3	
31500					33.7	0.45	126.9	
40000					40.3	0.4	148.9	
50000					47.6	0.4	184.9	
63000	56.2	0.35	222.3					



# 35kV Oil-Immersed Power Transformers

OVERVIEW

35kV series transformers are with the following characteristics: low loss, low noise, protection against thunder and lightning, high short-circuit withstand capacity and beautiful appearance etc. It is made by advanced assembling lines and method, with qualified and refined accessories. it enjoys four remote functions: "remote communication remote test, remote adjustment and remote control" . By remote control from a computer, the power station could be free from supervision in the office. 35kV series energy saving transformers have passed the identification Test by State Bureau of Machinery Industry, and State Power Corporation.

35kV series transformers are mainly used in urban and rural power grids and other industrial, mining enterprises, power transmission and distribution industry and also agriculture projects.

The core is processed by advanced vertical cut, horizontal cut, and stacking with stepped lap core and grade 3 seams. It disperses the air distribution, improves flux trend, thus, anddecreases the no-load loss, no-load current and noise.

The core uses particular adhesive for the plate, press ring, and silicon steel surface; and a range of overall structure and measures are used to increase the mechanical strength.

New structure of HV, LV windings and reasonable layout of oil duct and connecting area increases the capacity of mechanical strength and short-circuit withstand capacity.

The tank is bell type or core-lifting type, and the tank side is as corrugated form, with flowing lines, simplicity and beauty.

TECHNICAL PARAMETERS

50-1600/35 Series Three-phase Double-winding Distribution Transformers with Off-circuit Tap Changer

Rated Capacity (kVA)	Voltage Ratio(kv)		Vector Group	Loss values for S9 serial transformer		Loss values for S10 serial transformer		Loss values for S11 serial transformer		No-load current (%)	Impedance (%)	Weight		Outline Dimension			Gauge (mm)	
	HV	LV		No-load Loss	Full-load Loss	No-load Loss	Full-load Loss	No-load Loss	Full-load Loss			Oil weight	Total weight	L	W	H		
50	35	38.5±5% or ±2×2.5%	0.4	Yyn0 or Dyn11	0.21	1.21	0.19	1.15	0.17	1.15	2	6.5	275	740	1100	1000	1700	660
100					0.29	2.02	0.26	1.92	0.23	1.92	1.8		350	995	1100	1150	1750	660
125					0.34	2.03	0.31	2.26	0.27	2.26	1.7		430	1250	1100	1150	1800	660
160					0.36	2.83	0.32	2.69	0.29	2.69	1.6		450	1405	1160	1150	1860	660
200					0.43	3.33	0.39	3.16	0.34	3.16	1.5		495	1460	1230	1300	1950	660
250					0.51	3.96	0.46	3.76	0.41	3.76	1.4		520	1625	1250	1300	2000	660
315					0.61	4.77	0.55	4.53	0.49	4.53	1.4		590	1915	1400	1320	2070	820
400					0.73	5.76	0.66	5.47	0.58	5.47	1.3		680	2175	1510	1350	2150	820
500					0.86	6.93	0.77	6.58	0.69	6.58	1.2		760	2485	1620	1370	2240	820
630					1.04	8.28	0.94	7.87	0.83	7.78	1.1		830	2950	1750	1390	2330	820
800					1.23	9.9	1.11	9.41	0.94	9.41	1		880	3370	1900	1420	2400	820
1000					1.44	12.15	1.3	11.54	1.15	11.54	1		1005	4140	2165	1450	2485	820
1250					1.76	14.67	1.58	13.94	1.41	13.94	0.9		1160	4700	2230	1500	2600	1070
1600					2.21	17.55	1.91	16.67	1.7	16.67	0.8		1250	5570	2250	1650	2650	1070

630-2500/35 Series Three-phase Double-winding Distribution Transformers with Off-circuit Tap Changer

Rated Capacity (kVA)	Voltage Ratio(kv)		Vector Group	Loss values for S9 serial transformer		Loss values for S10 serial transformer		Loss values for S11 serial transformer		No-load Current (%)	Impedance (%)	Weight		Outline Dimension			Gauge (mm)	
	HV	LV		No-load Loss	Full-load Loss	No-load Loss	Full-load Loss	No-load Loss	Full-load Loss			Oil weight	Total weight	L	W	H		
630	35	38.5±5% or ±2×2.5%	6.3, 6.6, 10, 10.5, 11	Yd11	1.04	8.28	0.94	7.87	0.83	7.78	1.1	6.5	0.65	2.9	2100	1300	2300	820
800					1.23	9.9	1.11	9.4	0.98	9.4	1		0.7	3.2	2200	1350	2350	820
1000					1.44	12.15	1.3	11.54	1.15	11.54	1		0.85	3.5	2350	1450	2400	820
1250					1.76	14.67	1.58	13.94	1.41	13.94	0.9		1.01	3.84	2500	1600	2450	1070
1600					2.12	17.55	1.91	16.67	1.7	16.67	0.8		1.2	5	2600	1700	2500	1070
2000					2.72	19.35	2.45	18.38	2.18	18.38	0.7		1.28	6	2730	1800	2600	1070
2500	3.2	20.7	2.88	19.67	2.56	19.67	0.6	1.4	7	2870	1900	2700	1070					



# SZ 11-M Series Three Phase Oil Immersed Distribution Transformer

OVERVIEW

**Iron core:**

The iron core is made of high-permeability grain-oriented cold-rolled silicon steel sheet. Fully oblique seam stacked iron core, the iron core column has a multi-step circular cross section, and the iron yoke and the iron core have the same cross section.

**Coil:**

The firing group adopts corrugated oil passage, non-immersed paint process, and tightening banding; the firing group is all concentric coils; the high-voltage firing group has taps corresponding to the requirements of the tap voltage, which is led to the decomposition switch, and the switch is installed on the cover It is necessary to cut off the power before changing the tap voltage.

**Oil tank:**

The transformer oil tank is composed of corrugated walls, the surface is sprayed with dust, and the paint film is firm. The corrugated fins not only have the cooling function, but

also have the breathing function. The elasticity of the corrugated fins can compensate for the change in transformer oil volume caused by the temperature rise and fall. Therefore, the fully sealed transformer has no oil storage cabinet, which reduces the overall temperature of the transformer.

Transformer adopts vacuum oil injection process during packaging, which completely removes the moisture in the transformer, and the transformer oil is not in contact with air. Effectively prevent oxygen and moisture from intruding into the transformer, resulting in degradation of transformer insulation performance and aging of transformer oil, which improves the feasibility of transformer operation.

**Insulation structure:**

oil-immersed distribution transformer adopts A-level insulation structure; high voltage coil and low voltage coil are concentric; the space between coils is cardboard sleeve small oil clearance oil partition structure.

MODEL

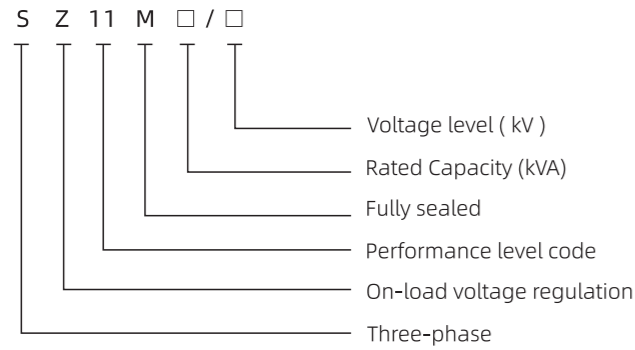

TECHNICAL PARAMETERS

Rated Capacity (kVA)	Voltage Combination			Vector Group	No-load Loss (W)	Load Loss 75°C (W)	No-load Current (%)	Impedance Voltage (%)	Exterior Size (L*W*H)	Total Weight (kg)
	High voltage (kV)	tap range	Low Voltage (kV)							
200	10	±4*2.5%	0.4	Yyn0	0.48	3.06	1.5	4	1650*870*1340	1040
250					0.56	3.6	1.4		1700*880*1490	1160
315					0.67	4.32	1.4		1750*900*1560	1360
400					0.8	5.22	1.3		1800*1060*1600	1550
500					0.96	6.21	1.2		1830*1080*1660	1820
630			Dyn11	1.2	7.65	1.1	4.5	1950*1120*1690	2170	
800				1.4	9.36	1.0		2270*1240*1840	2590	
1000				1.7	10.98	1.0		2310*1400*1900	3000	
1250				1.95	13.05	0.9		2360*1460*1940	3630	
1600				2.4	15.57	0.8		2430*1510*1990	4145	

**Note:** For transformers with rated capacity of 500 kVA and below, the load loss above the ramp in the table is applicable to the Dyn11 connection group, and the load loss below the ramp is applicable to the Yyn0 connection group.



# S11 Series Three Phase Oil Immersed Distribution Transformer

OVERVIEW

**Iron core:**

the iron core is made by crystal grain-oriented silicon-steel sheet; GEORG cross cut shear (made in West Germany) is adopted to cut the silicon-steel sheet with a 45° joint seam; fold the sheet into a multistage roll cross-section to reduce the noise and power consumption.

**Coil:**

cylinder type for high voltage; cylinder type or foil type for low voltage; this can increase the ability to resist short circuit and strike; and the distribution of magnetic path is more rational.

**Oil tank:**

the oil tank is made by fine cold-rolled steel sheets; GEORG corrugation oil tank production-line is adopted; to meet

environmental needs, then, antiseptic coating material is applied on the surface, which can meet the requirements for petroleum and chemical industry (much oil stain and many chemical substances). In addition, the corrugations not only possess heat radiation function, but also meet the requirement for oil expansion and oil contraction under normal performance. The isolation from air guarantees a low aging speed of oil and a long life expectancy of transformer.

**Insulation structure:**

oil-immersed distribution transformer adopts A-level insulation structure; high voltage coil and low voltage coil are concentric; the space between coils is cardboard sleeve small oil clearance oil partition structure.

MODEL

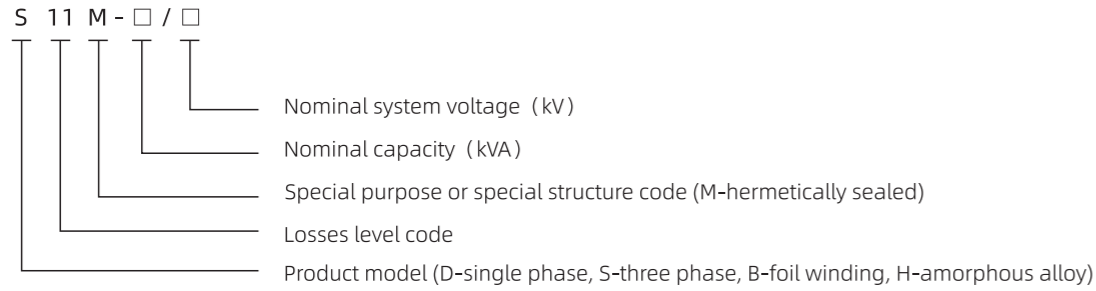

TECHNICAL PARAMETERS

Rated Capacity (kVA)	Voltage Combination			Vector Group	No-load Loss (W)	Load Loss (W)	No-load Current (%)	Impedance Voltage (%)	Total Weight (kg)	Exterior Size (L*W*H)(mm)	Installation center /Installation hole (mm)		
	High voltage (kV)	Tap range	Low voltage (kV)										
30	6	±5%	0.4	Ydn0	100	630/600	1.8	4.0	335	1030*690*860	400*400/4*φ14		
50					130	910/870	1.6		410	1045*700*925	400*400/4*φ14		
63					150	1090/1040	1.5		460	1075*710*940	400*400/4*φ14		
80					180	1310/1250	1.4		490	1080*715*995	400*400/4*φ19		
100					200	1580/1500	1.3		550	1110*730*1020	400*400(550)/4*φ19		
125					240	1890/1800	1.2		615	1135*740*1035	400*400(550)/4*φ19		
160					280	2310/2200	1.1		695	1155*755*1050	550*550/4*φ19		
200					340	2730/2600	1		790	1200*770*1075	550*550/4*φ19		
250				400	3200/3050	0.9	930	1240*800*1100	550*550/4*φ19				
315				10	±2*2.5%	Dyn11	480	3830/3650	0.8	4.5	1110	1305*840*1120	550*550/4*φ19
400				570			4520/4300	0.7	1290		1390*900*1160	660*660/4*φ19	
500				680			5410/5150	0.7	1510		1500*990*1195	660*660/4*φ19	
630				810			6200	0.6	1730		1580*1030*1305	660*660/4*φ19	
800				980			7500	0.6	2075		1705*1140*1360	820*820/4*φ19	
1000				1150			10300	0.5	2490		1730*1290*1395	820*820/4*φ19	
1250				1360			12000	0.4	2960		1780*1320*1480	820*820/4*φ19	
1600	1640	14500	0.4	3515			1890*1430*1520	820*820/4*φ19					
2000	1940	18300	0.4	4880	2050*1360*1840	820*820/4*φ19							
2500	2290	21200	0.4	5	6010	2170*1430*2015	1070*1070/4*φ19						

**Note:** For transformers with rated capacity of 500 kVA and below, the load loss above the ramp in the table is applicable to the Dyn11 connection group, and the load loss below the ramp is applicable to the Yyn0 connection group.



## S9 Series Three Phase Oil Immersed Distribution Transformer

OVERVIEW

**Iron core:**

The iron core is made of cold-rolled grain-oriented silicon steel sheets with high magnetic conductivity, with inclined joint laminated structure. Section of the core limbs is of multi-class ladder round, with uniform section with that of yoke.

**Winding:**

The winding adopts corrugated oil duct with non-dipping process, bound by shrinkable tape; all windings are of concentric coils; taps of HV winding with corresponding tapping voltage shall be led to the tap switch, and the switch shall be installed on the box cover. Power supply must be cut off first when changing the tapping voltage.

**Oil tank:**

Transformer oil tank is composed of corrugated walls with powder painted surface and reinforced with film. Corrugated cooling fin not only has cooling function, but also has breathing function, the elasticity of corrugated cooling fin make it adapt to the change of oil volume due to change temperature. So this hermetically sealed transformer does not have oil conservator, which decreases 1h& height of transformer.

The transformer adopts vacuum oil-injection technology during encapsulation that thoroughly removes the moisture from transformer, and keeps the transformer oil from contacting the air. This is technology also avoid insulation performance reduction or oil aging due to entering of oxygen or moisture, it improves operation reliability of transformer.

MODEL

S 9 M - □ / □

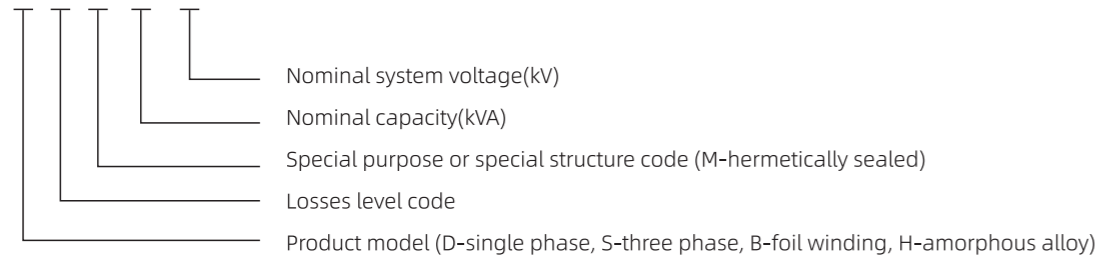

TECHNICAL PARAMETERS

Rated Capacity (kVA)	Voltage Combination			Vector Group	No-load Loss (W)	Load Loss (75°C)(W)	No-load Current (%)	Impedance Voltage (%)	Exterior Size (L*W*H)	Total Weight (kg)
	High voltage (kV)	Tap range	Low voltage (kV)							
800	35 38.5	±5% or ±2*2.5%	3.15 6.3 10.5	Yd11	1.23	9.90	1.0	6.5	2140*1320*2120	3040
1000					1.44	12.15	1.0		2400*1330*2170	3410
1250					1.76	14.67	0.9		2470*1350*2190	3890
1600					2.12	17.55	0.8		2550*1375*2250	4620
2000					2.72	19.35	0.7		2700*1400*2300	5345
2500					3.20	20.70	0.6		2520*2300*2365	5960
3150					3.80	24.30	0.56		2600*2350*2410	6695
4000					4.52	28.80	0.56		2680*2560*2490	8350
5000				5.40	33.03	0.48	2730*2750*2550	9400		
6300				6.56	36.90	0.42	2960*2800*3080	11300		
8000				9.00	40.50	0.42	3170*2610*3210	13240		
10000				10.88	47.70	0.40	3250*3220*3400	16600		
12500				12.60	56.70	0.40	3370*3260*3540	19400		
16000				15.20	69.30	0.40	3470*3280*3580	23100		
20000				18.00	83.70	0.40	3950*3450*3850	29700		
25000				21.28	99.00	0.32	4570*3800*3900	38200		
31500	25.28	118.80	0.32	5000*4150*4000	40300					



# S13-M Series Three Phase Oil Immersed Distribution Transformer

OVERVIEW

**Iron core:**

The iron core and the burning group each adopt fastening measures, which can withstand the shock of transportation. The coil and iron core are vacuum-dried, and the transformer oil is vacuum-filtered and oil-filled to minimize moisture inside the transformer.

**Oil tank:**

The oil tank uses a corrugated sheet, which has a breathing function to compensate for the volume change of oil caused by temperature changes, so the product does not have an oil storage cabinet, which obviously reduces the height of the transformer. Because the corrugated sheet replaces the oil storage cabinet, the transformer oil is isolated from the outside world, effectively preventing the infiltration of oxygen and water.

MODEL

S 13 M - □ / □

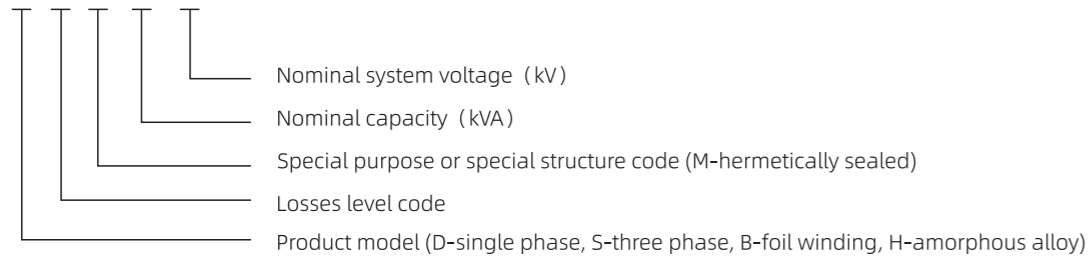

TECHNICAL PARAMETERS

Model	Rated Capacity (kVA)	Voltage Combination		Vector Group	No-load Loss (w)	Load Loss (75°C)(w)		No-load Current (%)	Impedance Voltage (%)
		High voltage (kV)	Low voltage (kV)			Dy	Yy		
S13-M-10	10	10	0.4	Yd11 or Dyn11	40	360	340	2.8	4.0
S13-M-20	20				70	525	500	2.5	
S13-M-30	30				80	630	600	2.3	
S13-M-50	50				100	910	870	2.0	
S13-M-63	63				110	1090	1040	1.9	
S13-M-80	80				130	1310	1250	1.8	
S13-M-100	100				150	1580	1500	1.8	
S13-M-125	125				10	1890	1800	1.7	
S13-M-160	160				200	2310	2200	1.6	
S13-M-200	200				240	2730	2600	1.5	
S13-M-250	250				290	3200	3050	1.4	
S13-M-315	315				340	3830	3650	1.4	
S13-M-400	400				410	4520	4300	1.3	
S13-M-500	500				480	5410	5150	1.2	
S13-M-630	630				570	6200	6200	1.1	
S13-M-800	800				700	7500	7500	1.0	
S13-M-1000	1000				830	10300	10300	1.0	4.5
S13-M-1250	1250				970	12000	12000	0.9	
S13-M-1600	1600				1170	14500	14500	0.8	
S13-M-2000	2000				1510	17800	17800	0.8	
S13-M-2500	2500	1780	20700	20700	0.7	5.0			
S13-M-3150	3150	2100	24300	24300	0.7				



# S13-M.RL Series Three Phase Oil Immersed Distribution Transformer

OVERVIEW

**Iron core:**

The three-dimensional triangle roll is intimately composed of three identical single frames. The three core posts are arranged in an equilateral triangle. The magnetic path length of the three core posts is completely the same, and the shortest. The loss of the three core posts is the same, so the three-phase magnetic circuit is balanced. The production efficiency is improved. The three-dimensional triangular wound core is the same as the planar wound core in that it is rolled on the production line to eliminate the quality fluctuations caused by manual lamination and stacking of the stacked iron core. At the same time, the body structure of the three-dimensional triangular wound iron core transformer determines that its short circuit resistance is better than that of the planar transformer.

**Oil tank:**

The appearance is beautiful, the transformer oil tank adopts a near-micro triangle structure, so the volume is smaller than the conventional rectangular oil tank, the structure is compact, and the appearance is beautiful.

MODEL

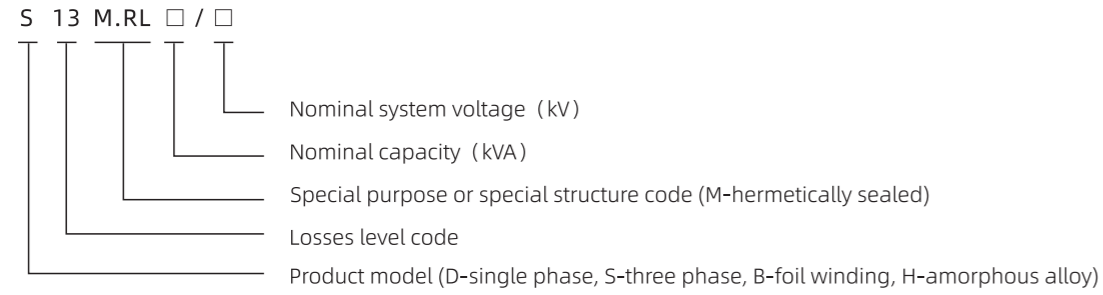

TECHNICAL PARAMETERS

Model	Rated Capacity (kVA)	Voltage Combination(kv)			Vector Group	No-load Loss (w)	Load loss (w)		No-load Current (%)	Short circuit Impedance (%)
		High voltage	Tapping range	Low voltage			Dy	Yy		
S13-M.RL-30	30	10	±5%	0.4	Yyn0	80	630	600	2.3	4.0
S13-M.RL-50	50					100	910	870	2.0	
S13-M.RL-80	80					130	1310	1250	1.9	
S13-M.RL-100	100					150	1580	1500	1.8	
S13-M.RL-125	125					170	1890	1800	1.7	
S13-M.RL-160	160					200	2310	2200	1.6	
S13-M.RL-200	200					240	2730	2600	1.5	
S13-M.RL-250	250					290	3200	3050	1.4	
S13-M.RL-315	315					340	3830	3650	1.4	
S13-M.RL-400	400					6.3	±2*2.5%	0.4	or Dyn11	
S13-M.RL-500	500	480	5410	5150	1.2					
S13-M.RL-630	630	570	6200	6200	1.1					
S13-M.RL-800	800	700	7500	7500	1.0					
S13-M.RL-1000	1000	830	10300	10300	1.0					
S13-M.RL-1250	1250	970	12000	12000	0.9					
S13-M.RL-1600	1600	1170	14500	14500	0.8					
S13-M.RL-2000	2000	1510	17800	17800	0.8					
S13-M.RL-2500	2500	1780	20700	20700	0.7					
S13-M.RL-3150	3150	2100	24300	24300	0.7	According to customer requirements				



# S(B)H15-M Series Three Phase Dry-type Distribution Transformer

OVERVIEW

**Iron core:**

The three-dimensional triangle roll is intimately composed of three identical single frames. The three core posts are arranged in an equilateral triangle. The magnetic path length of the three core posts is completely the same, and the shortest. The loss of the three core posts is the same, so the three-phase magnetic circuit is balanced. The production efficiency is improved. The three-dimensional triangular wound core is the same as the planar wound core in that it is rolled on the production line to eliminate the quality fluctuations caused by manual lamination and stacking of the stacked iron core. At the same time, the body structure of the three-dimensional triangular wound iron core transformer determines that its short circuit resistance is better than that of the planar transformer.

**Oil tank:**

The appearance is beautiful, the transformer oil tank adopts a near-micro triangle structure, so the volume is smaller than the conventional rectangular oil tank, the structure is compact, and the appearance is beautiful.

MODEL

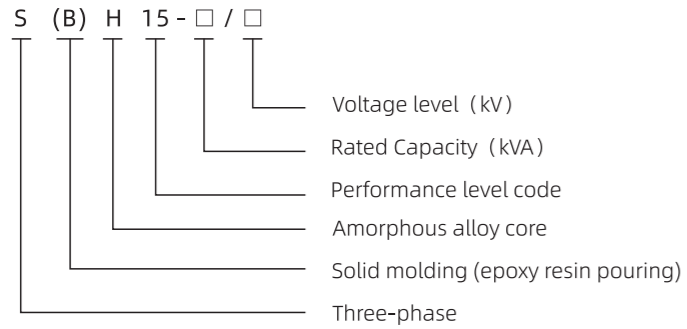

TECHNICAL PARAMETERS

Rated Capacity	High Voltage	Tap Range	Low Voltage	Vector Group	No-load Loss	Load Loss	No-load Current	Impedance Voltage	Sound Power Level	Exterior Size L*W*H	Total Weight			
(kVA)	(kV)		(kV)		(W)	(75°C)(W)	(%)	(%)	(dB)	(L*W*H)	(kg)			
30	6	±2*2.5	0.4	Dyn11	33	630/600	1.5	4	52	800*500*800	300			
50					43	910/870	1.2		53	820*550*800	350			
63					50	1090/1040	1.1		53	835*580*800	380			
80					60	1310/1250	1.0		55	840*600*830	400			
100					75	1580/1500	0.9		55	860*600*860	440			
125					85	1890/1800	0.8		59	1020*660*900	560			
160					100	2310/2200	0.6		59	1035*660*900	620			
200					120	2730/2600	0.6		61	1040*680*930	680			
250				6.3	±5	0.4	Yzn11	140	3200/3050	0.6	4.5	61	1140*740*960	800
315				6.6				170	3830/3650	0.5		64	1160*760*1100	920
400				10				200	4520/4300	0.5		64	1230*800*1150	1080
500				10.5				240	5410/5150	0.5		66	1320*900*1150	1285
630				11				320	6200	0.3		66	1420*920*1180	1580
800								380	7500	0.3		68	1480*1000*1235	1900
1000								450	10300	0.3		68	1600*1100*1280	2155
1250								530	12000	0.2		72	1655*1135*1325	2515
1600		630	14500	0.2	72	1815*1260*1400	3050							
2000		750	18300	0.2	73	1920*1305*1460	3735							
2500		900	21200	0.2	73	2120*1430*1525	4520							



## D10-M Series Single Phase Oil Immersed Distribution Transformer

OVERVIEW

**Iron core:**

**Effectively upgrade transformer's no-load performance by below methods:**

1) The core is made of high-permeable grain-orientated top quality cold-rolled silicon sheet and the material is cut with advanced Germany Geoge GmbH automatic shear line with the cut burs controlled within 0.02mm.

2) The silicon sheet fabrication adopts "no-upper yoke lapped" technology and all lapped joints of the silicon sheet are 45 full-miters. The laminated core sheets are integrally pressed and adhered with epoxy resin to make the three leg two-yoke core a strong and flat integral one with good verticality precision, this effectively improves no-load performance and reduces noises.

**Winding:**

1) The high-voltage (HV) coil adopts an interleaved-continuous structure to improve the voltage characteristics under impact voltage and make voltage evenly distributed. All stays and pads are chamfered to keep highly reliable insulation.

2) In the transformer winding there is a zigzag oil guide structure so as to fully cool all areas inside the winding, lower the temperature rise of the winding and the hot points of the winding and prolong the service life of insulation. The HV and MV regulation system are independently provided with voltage-regulating winding to balance the ampere turn of each winding, effectively lower the axial electrodynamic force generated at short-circuit of transformer and improve abrupt short-circuit withstanding capacity.

**Oil tank and accessories:**

1) The tank wall adopts wide steel sheet, which will be folded into corrugated structure without splicing, in this way welds are decreased and mechanical strength is enhanced, meanwhile, the corrugated wall has diverging effect, and thus plays a role in decrease of noise. The routing troughs and control cabinets of the secondary circuit are all made of stainless steel, so the entire transformer has a simple and good looking.

2) All sealing surface use quality sealing material and are precision-machined.

MODEL

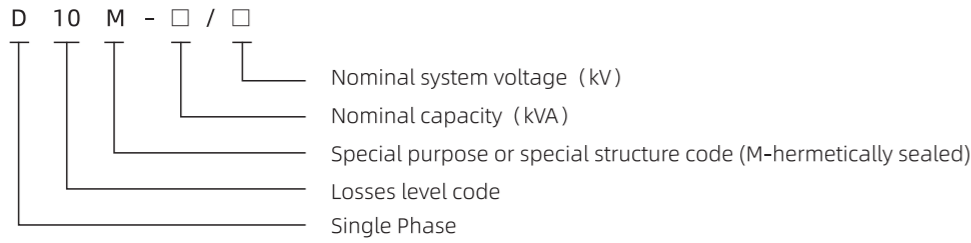

TECHNICAL PARAMETERS

Rated Capacity (kVA)	Voltage Ratio(KV)		Vector Group	Impedance	Losses		No-load Current (%)	Weight			Dimension (L*W*H)
	HV	LV			No load	Load		Machine weight	Oil	Gross	
5	11 10.5 10 6.3 6	0.22 0.24	Lio li6	3.5	35	145	4	50	40	130	530*450*850
10					55	260	3.5	65	40	150	560*450*870
16					65	365	3.2	80	40	180	600*450*920
20					80	430	3.0	100	50	205	620*450*940
30					100	325	2.5	115	50	225	700*450*980
40					125	775	2.5	150	55	270	700*480*1040
50					150	950	2.3	175	70	310	650*510*1100
63					180	1135	2.1	190	80	340	660*520*1100
80					200	1400	2.0	240	100	420	770*530*1120
100					240	1650	1.9	295	100	490	840*600*1150
125					285	1950	1.8	370	110	560	890*740*1160
160					365	2365	1.7	430	130	650	950*790*1170

Note: Tapping range of high voltage: ±5%, ±2\*2.5%; Frequency 50Hz

Rated Capacity (kVA)	Voltage Ratio(KV) High voltage	Tapping Range (%)	LV (KV)	Losses		Weight	
				No load	Full load Loss	Oil	Gross
15	33/19 30/17.3 13.2/7.62 11/6.35	±2*2.5%; Or other	0.12	0.03	0.195	45	294
25			0.24	0.05	0.4	68	362
37.5			0.48 or	0.65	0.5	75	476
50			0.12-	0.8	0.6	93	553
75			0.24	0.12	0.88	132	672
100			0.24-	0.21	1.12	141	742
167			0.48	0.35	1.41	207	952
250				0.5	2.0	375	1386



## SC(B) Series Three Phase Dry-type Distribution Transformer

### OVERVIEW

**Iron core:**

The iron core is made of imported high-quality cold-rolled silicon steel sheet, with a fully oblique seam structure, the core column is bound with F-grade non-lattice tape, and the surface of the iron core is encapsulated with epoxy resin, which reduces no-load loss, no-load current and iron core noise, clips and fasteners are treated with special surface treatment, which further improves the appearance quality of the product.

**High voltage winding:**

The high-voltage windings are vacuum cast with filled epoxy resin, which greatly reduces the partial discharge and improves the electrical strength of the coil. The inner and outer walls of the winding are filled with glass fiber grid plates to enhance the mechanical strength of the coil and improve the product's resistance to sudden short circuits. The ability of the coil to never crack.

**Low voltage winding:**

The low-voltage winding adopts a foil structure, which solves the problem of the axial helix angle when winding the wire and makes the turns more balanced. At the same time, the coil adopts an axial cooling air duct to enhance the heat dissipation capacity. The winding layer adopts TD epoxy resin prepreg. The whole is solidified and formed.

**Temperature control system and air cooling system:**

The cross-flow top-blowing cooling fan is adopted, which has the characteristics of low noise, high wind pressure and beautiful appearance, which enhances the overload capacity of the transformer. The temperature control adopts an intelligent temperature controller, which improves the safety and reliability of transformer operation.

MODEL

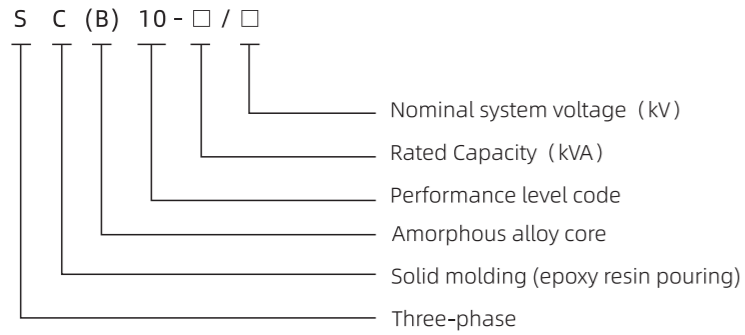

TECHNICAL PARAMETERS

Rated Capacity	Voltage Ratio (kV)		Vector Group	Loss Values for S10 Serial Transformer			No-load Current (%)	Impedance (%)	Weight (kg)	Outline Dimension			Gauge (mm)
	(kVA)	HV		LV	No-load loss(W)	Full-load loss(W)(145°C)				(%)	(%)	(kg)	
30				190	710	2			240	800(1150)	440(900)	800(1200)	400
50				270	1000	1.8			310	850(1200)	440(900)	820(1300)	400
80				370	1380	1.6			470	900(1200)	660(900)	850(1300)	550
100				400	1570	1.6			520	950(1250)	660(1000)	890(1350)	550
125				470	1850	1.2			600	950(1300)	660(1000)	940(1350)	550
160	6			550	2130	1.2	4		700	1000(1400)	660(1100)	920(1400)	550
200	6.3			630	2530	1			830	1050(1400)	820(1100)	970(1450)	550
250	6.6			720	2760	1			1050	1150(1500)	860(1100)	1090(1500)	550
315	10			880	3470	1			1200	1150(1600)	860(1200)	1150(1550)	550
400	11	0.4	Dyn11 or Yyn0	980	3990	0.9			1500	1250(1600)	920(1300)	1230(1600)	660
500	±5%			1160	4880	0.9			1700	1300(1700)	960(1300)	1400(1700)	660
630	or			1350	5880	0.8			1900	1350(1800)	960(1300)	1430(1750)	820
630	±2*			1300	5960	0.8			1950	1400(1800)	980(1300)	1450(1750)	820
800	2.5%			1520	6960	0.8			2150	1450(1800)	980(1300)	1480(1800)	820
1000				1770	8130	0.8			2550	1500(1900)	1020(1400)	1540(1900)	820
1250				2090	9690	0.7	6		2900	1600(2000)	1020(1400)	1610(1900)	820
1600				2450	11730	0.6			3500	1750(2150)	1020(1400)	1680(2100)	820
2000				3050	14450	0.5			4300	1900(2300)	1060(1500)	1760(2200)	1070
2500				3600	17170	0.5			5100	2050(2400)	1060(1500)	1840(2200)	1070

TECHNICAL PARAMETERS

Rated capacity (kVA)	Voltage Ratio (kV)		Vector Group	Loss values for S10 serial transformer		No-load current (%)	Impedance (%)
	HV	LV		No-load loss(W)	Full-load loss (W)(145°C)		
30				360	1140	2.8	
50				450	1425	2.6	
80				540	1805	2.2	
100				630	2090	2	
125				700	2420	1.8	
160				790	2810	1.8	
200	35			880	3325	1.6	
250	38.5			990	3800	1.6	
315	±5%			1175	4510	1.4	
400	or	0.4	Dyn11 or Yyn0	1375	5415	1.4	6
500	±2*			1620	6650	1.4	
630	2.5%			1860	7695	1.2	
800				2160	9120	1.2	
1000				2430	10450	1	
1250				2835	12730	1	
1600				3240	15485	0.8	
2000				3825	18240	0.7	
2500				4455	21850	0.7	



# SC(B)10-RL Series Three Phase Dry-type Distribution Transformer

## OVERVIEW

### Iron core:

The three-dimensional triangle structure is adopted, and the arrangement of the iron cores is more rationally combined. Three identical single frames are used to form a three-dimensional equilateral triangle, so that the three-phase iron core magnetic circuit of the product is completely symmetrical and equal in length. Ensure that the three-phase power supply is balanced, and the magnetic resistance is greatly reduced, and the excitation current and no-load loss are significantly reduced. The iron core curing adopts the exclusive curing process of three-dimensional triangular wound iron core, and the curing effect is good. Ensure that the iron core is not deformed during assembly, transportation and operation, thereby reducing the no-load loss and noise of the iron core.

### Winding:

The coil is composed of a high-voltage coil and a low-voltage coil. The low-voltage coil has a foil or cylindrical structure, and the end insulation is sealed with a resin compound; the high-voltage coil adopts a segmented Japanese barrel structure, and the epoxy resin and curing agent are selected from Huntsman The Ministry of Fine Chemical Industry (HUNTSMAN) is a high-grade insulating material, and the entire coil conductor is enclosed by a solid insulating layer of epoxy resin, so not only is it difficult to penetrate moisture, but also completely prevents the conductor from being exposed to various harmful gases and corrosive chemicals. It is possible to damage the ingredients, so its moisture-proof and anti-fouling performance is particularly good.

Use OMO between layers. The pre-impregnated cloth is formed by heat curing, and it is put into an oven to cure after winding processing to make it have extremely strong short-circuit resistance ability. According to the maximum capacity of the transformer, a shaft heat dissipation duct that can dissipate heat in both directions is provided on the inner layer of the coil.

## MODEL

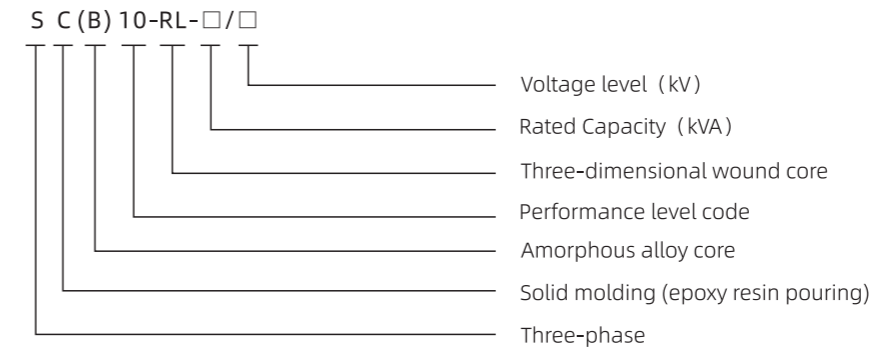

## TECHNICAL PARAMETERS

Rated Capacity (kVA)	Voltage Combination			Vector Group	No-load Loss (W)	Load loss (W)			No-load Current (%)	Impedance Voltage (%)	Exterior Size (L*W*H)	Total Weight (kg)			
	High voltage (kV)	tap range	Low Voltage (kV)			130°C(B) 100°C	155°C(F) 120°C	180°C(H) 145°C							
30	6	±2.5	0.4	Dyn11	190	670	710	760	2.3	4.0	900*900*800	300			
50					270	940	1000	1070	2.2		955*900*900	350			
80					370	1290	1380	1480	1.7		985*950*960	400			
100					400	1480	1570	1690	1.7		1035*1250*980	450			
125					470	1740	1850	1980	1.5		1060*1280*1000	500			
160		6.3			±5	0.4	Dyn11	540	2000	2130	2280	1.5	6.0	1120*1320*1050	680
200								620	2370	2530	2710	1.3		1135*1330*1105	770
250								720	2590	2760	2960	1.3		1170*1330*1165	900
315								880	3270	3470	3730	1.1		1185*1360*1225	1010
400								980	3570	3990	4280	1.1		1210*1380*1300	1205
500	6.6	±2*2.5	0.4	Dyn11	1160	4590	4880	5230	1.1	8.0	1245*1400*1380	1400			
630					1340	5530	5880	6290	0.9		1295*1410*1355	1515			
630					1300	5610	5960	6400	0.9		1295*1410*1355	1515			
800					1520	6550	6960	7460	0.9		1375*1450*1480	1880			
1000					1770	7650	8130	8760	0.9		1430*1480*1525	2170			
1250	10	±5	0.4	Dyn11	2090	9100	9690	10300	0.9	8.0	1480*1500*1570	2525			
1600					2450	11000	11700	12500	0.9		1500*1520*1710	2980			
2000					3050	13600	14400	15500	0.7		1570*1550*1735	3480			
2500					3600	16100	17100	18400	0.7		1625*1600*1825	4080			
1600					2450	12200	12900	13900	0.9		1500*1520*1710	2980			
2000	10.5	±5	0.4	Dyn11	3050	15000	15900	17100	0.7	8.0	1570*1550*1735	3480			
2500					3600	17700	18800	20200	0.7		1625*1600*1825	4080			

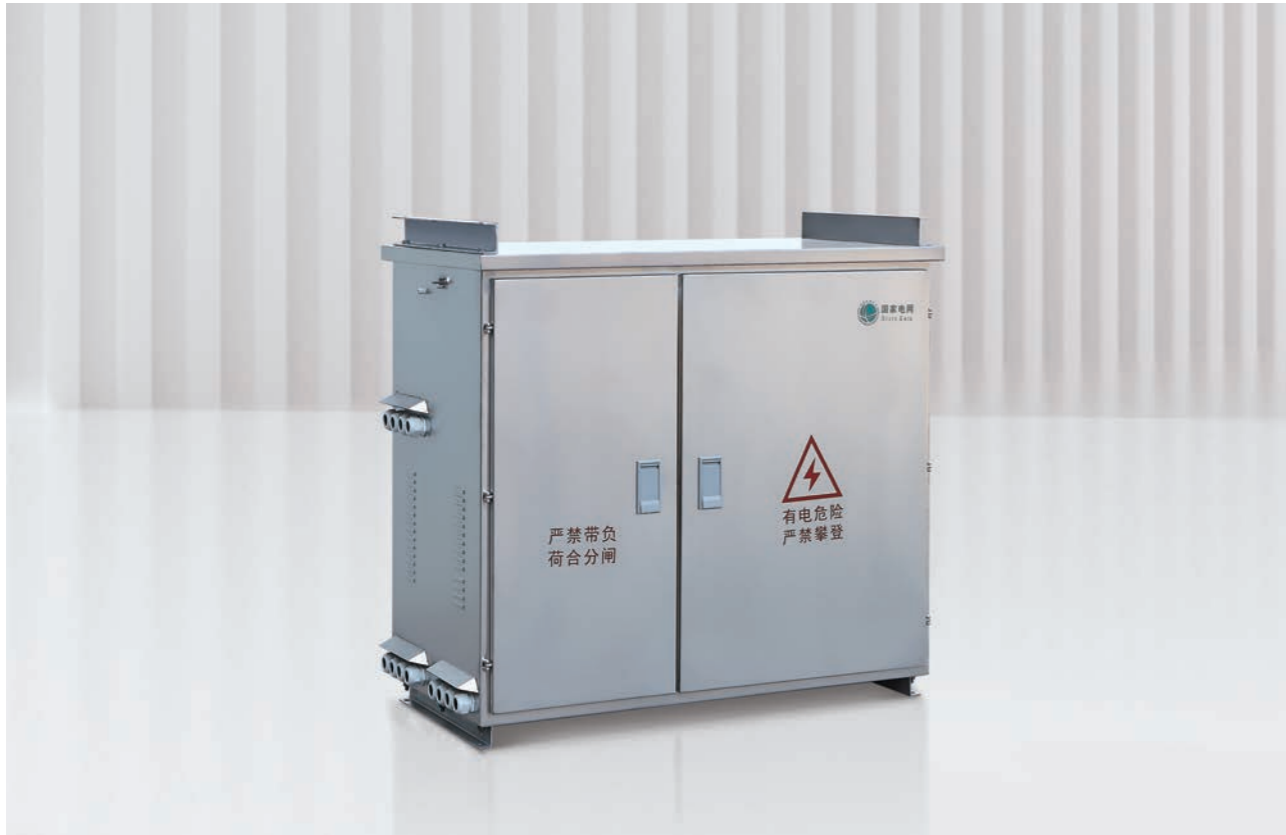

## JP Cabinet

### OVERVIEW

Outdoors integrated distribution cabinet series is suitable for AC 50 Hz, rated voltage up to 0.4 kV power transmission and distribution system. This series of product is a combination of automatic compensation and power distribution. And it is a innovative indoors and outdoors pressure distribution cabinet of electrical leakage protection, energy metering, over-current, over-pressure open phase protection. It has benefits of small volume, easy installation, low cost,

electricity-stolen prevention, strong adaptability, resistance to aging, accurate rotor, no compensation error, etc. Therefore it is the ideal and preferred product for electric grid reformation.

### PRODUCT SHELL

The product is made of bending and welding of high quality stainless steel. Compared with other distribution boxes made of cold steel, its tensile ability, oxidation resistance, corrosion resistance has been greatly strengthened, and it extends the service life of the equipment. Novel design shows scientific innovation and achievements. On the other hand, V-type box is equipped with sealing rubber strip, which can prevent the dust, and it is fitted with floor at the same time. It can be installed electrical equipment. The open angle is greater than 90 degrees. It is adopted the new design: waterproof, anti-theft, anti-dust. And organic glass has been adopted to increase safety, easily installation and operation. Specifications, sizes can be customized according to customers' requests.

### PRODUCT FUNCTION

Outdoors integrated distribution box -JP series is designed according to reformation requirements and operational experience of grid construction, based on the principle of security, economic, reasonable and reliable. It is a new type outdoors integrated distribution box with functions of power distribution, controlling, protection, reactive power compensation, power metering. At the same time the electric leakage protection can be added according to users' requirements. The product has several benefits: novel structure, reasonable, high protection grade, convenient installation, debugging, maintenance and repair, etc. The product conforms to standard GB7251.1-1997, and passed 3C certification. It is the ideal low-voltage apparatus in reformation of power grids. Outdoors integrated distribution box -JP series is suitable for 0.4 kV voltage grade of power distribution, metering, protection and automatic reactive power compensation.

### TECHNICAL PARAMETERS

<b>Rated voltage</b>	400 V
<b>Rate frequency</b>	50 Hz
<b>Transformer capacity</b>	30,50,63,80,100,125,160,200,250,315(kVA)
<b>Capacitor grouping</b>	(in general)2,3,4,5;can be adjusted according to customer's special requirements
<b>Feeder circuit</b>	3 roads generally, for each road, distribute according to its transformer's 40-60% of total capacity, can be adjusted according to customers' special requirements
<b>Compensation mode</b>	circulation cutting, coding cutting, fuzzy control automatic cutting
<b>Control parameters</b>	reactive power or reactive current
<b>Fastest response time</b>	20 ms or less

**Note:** Tapping range of high voltage:  $\pm 5\%$ ,  $\pm 2*2.5\%$ ; Frequency 50Hz

